

# Appendix 1

## Positive Switching Charge Regulator

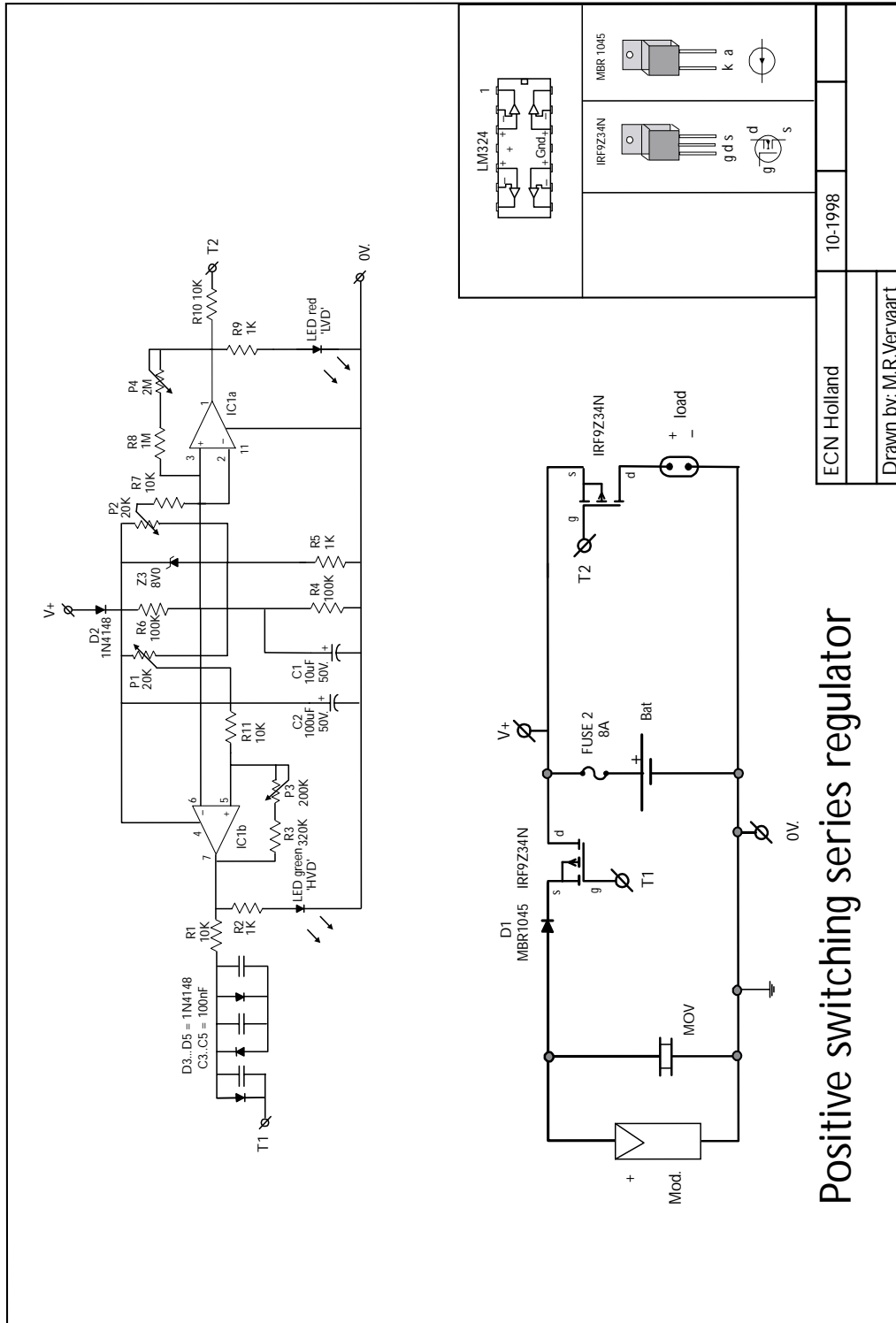

# Appendix 2

## Block Diagram of a Modified Charge Regulator

### Component reduction

Actual diagram

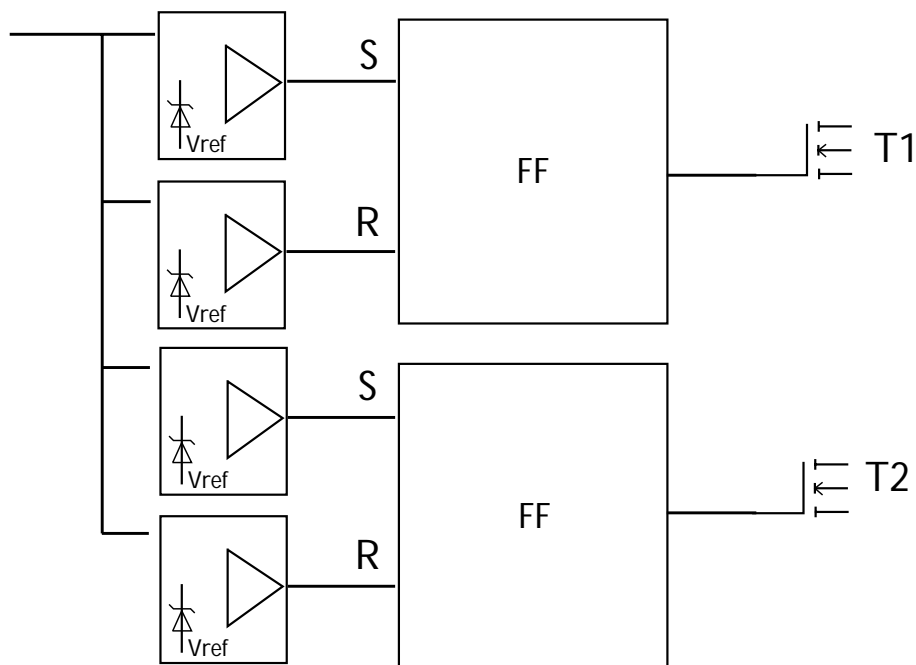

Possible setup (exactly the same functions)

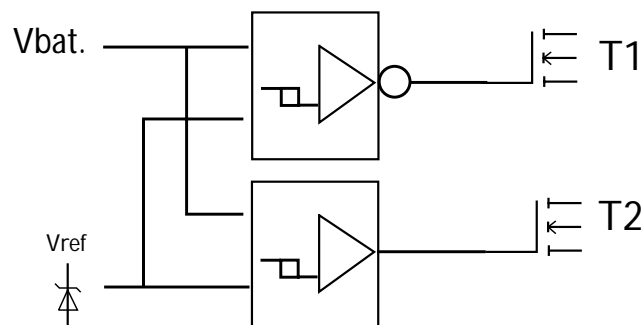

# Appendix 3

## Data Sheet IRFZ40



**IRFZ40  
IRFZ40FI**

**N - CHANNEL ENHANCEMENT MODE  
POWER MOS TRANSISTORS**

TYPE	V <sub>DSS</sub>	R <sub>DS(on)</sub>	I <sub>D</sub>
IRFZ40	50 V	< 0.028 Ω	50 A
IRFZ40FI	50 V	< 0.028 Ω	27 A

- TYPICAL R<sub>DS(on)</sub> = 0.022 Ω
- AVALANCHE RUGGED TECHNOLOGY
- 100% AVALANCHE TESTED
- REPETITIVE AVALANCHE DATA AT 100°C
- LOW GATE CHARGE
- HIGH CURRENT CAPABILITY
- 175°C OPERATING TEMPERATURE

#### APPLICATIONS

- HIGH CURRENT, HIGH SPEED SWITCHING
- SOLENOID AND RELAY DRIVERS
- REGULATORS
- DC-DC & DC-AC CONVERTERS
- MOTOR CONTROL, AUDIO AMPLIFIERS
- AUTOMOTIVE ENVIRONMENT (INJECTION, ABS, AIR-BAG, LAMPDRIVERS, Etc.)

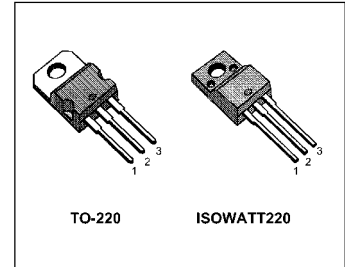

TO-220

ISOWATT220

#### INTERNAL SCHEMATIC DIAGRAM

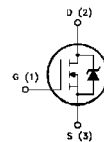

#### ABSOLUTE MAXIMUM RATINGS

Symbol	Parameter	Value		Unit
		IRFZ40	IRFZ40FI	
V <sub>DS</sub>	Drain-source Voltage (V <sub>GS</sub> = 0)	50	50	V
V <sub>DGR</sub>	Drain- gate Voltage (R <sub>GS</sub> = 20 kΩ)	50	50	V
V <sub>GS</sub>	Gate-source Voltage	± 20		V
I <sub>D</sub>	Drain Current (cont.) at T <sub>c</sub> = 25 °C	50	27	A
I <sub>D</sub>	Drain Current (cont.) at T <sub>c</sub> = 100 °C	35	19	A
I <sub>DM(*)</sub>	Drain Current (pulsed)	200	200	A
P <sub>tot</sub>	Total Dissipation at T <sub>c</sub> = 25 °C	150	45	W
	Derating Factor	1	0.3	W/°C
V <sub>ISO</sub>	Insulation Withstand Voltage (DC)	2000		V
T <sub>stg</sub>	Storage Temperature	-65 to 175		°C
T <sub>j</sub>	Max. Operating Junction Temperature	175		°C

(\*) Pulse width limited by safe operating area

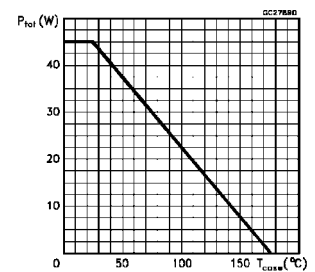
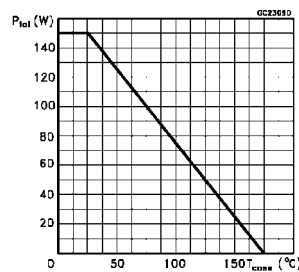

#### Output Characteristics

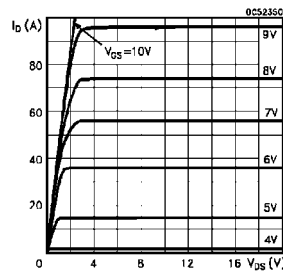

#### Transfer Characteristics

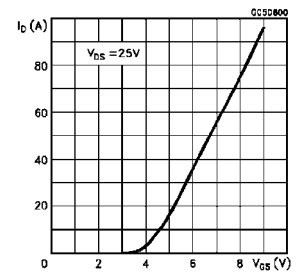

# Appendix 4

## Negative Switching Shunt Regulator

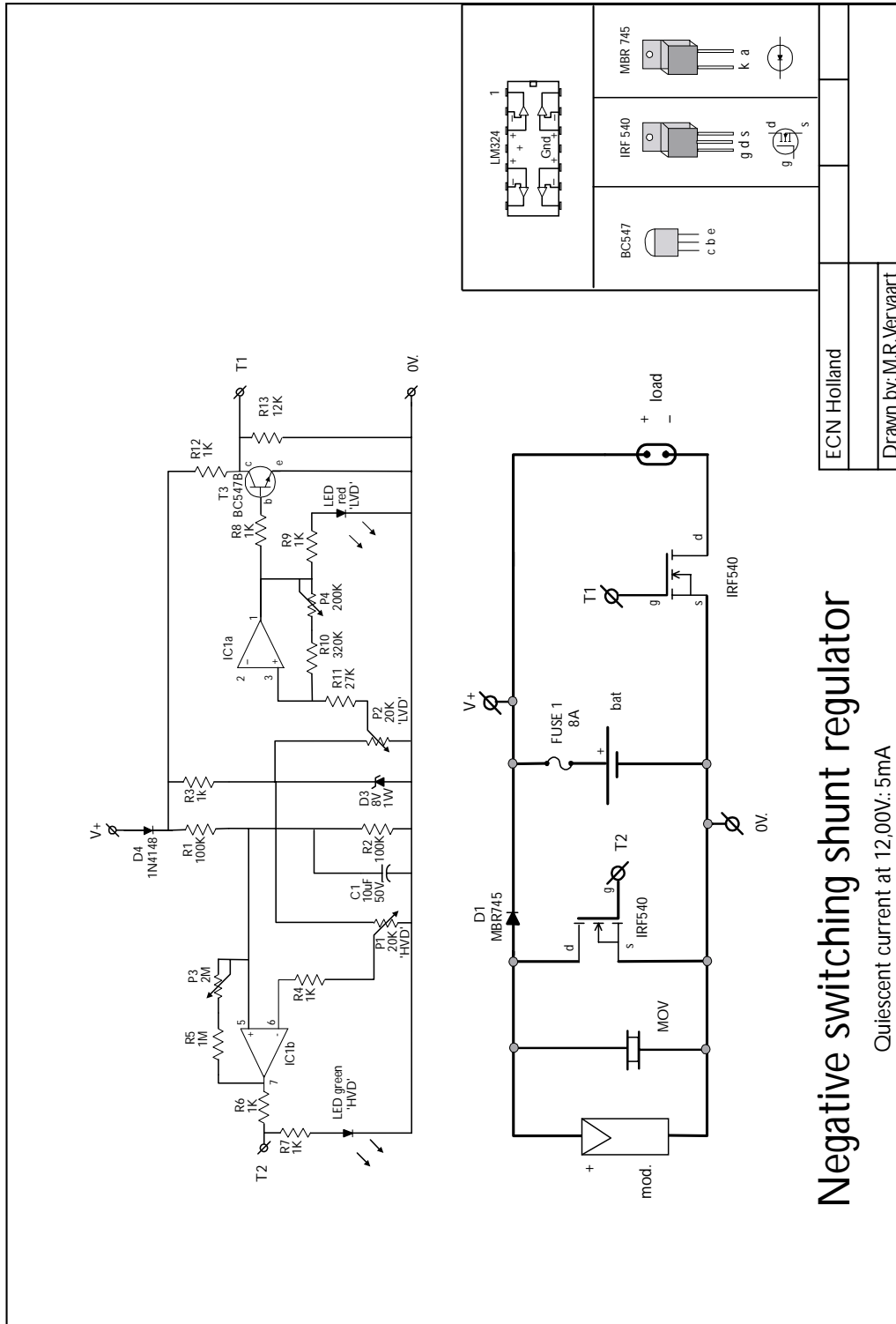

**Negative switching shunt regulator**

Quiescent current at 12,00V: 5mA

# Appendix 5

## Negative Switching Shunt Regulator with E-Fuse

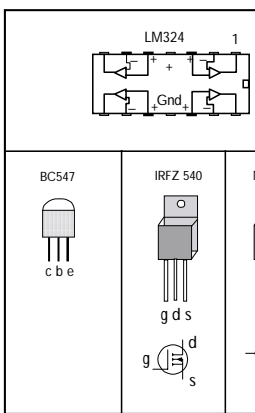
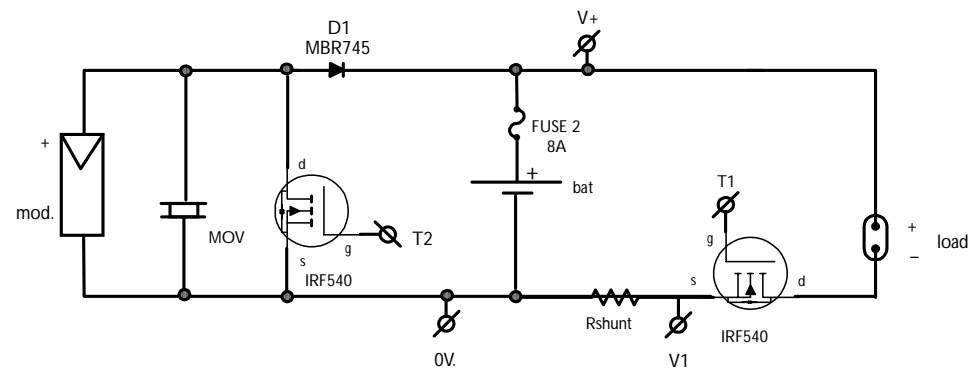
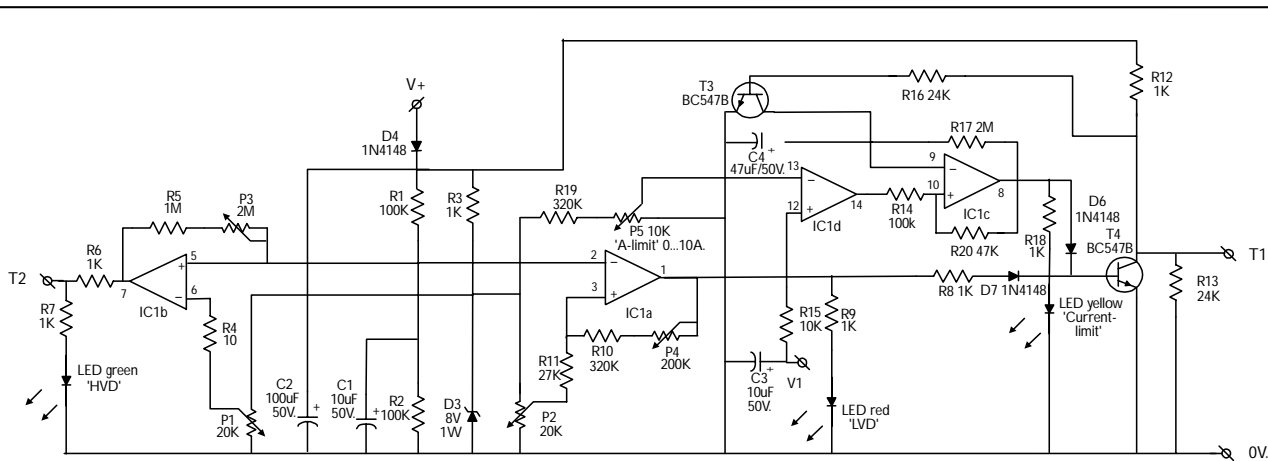

Negative switching shunt regulator with E-fuse

Quiescent current at 12,00V: 4mA.

ECN Holland	9-1998
Drawn by: M.R.Vervaart	

# Appendix 6

## Positive Switching Charge Regulator with E-Fuse

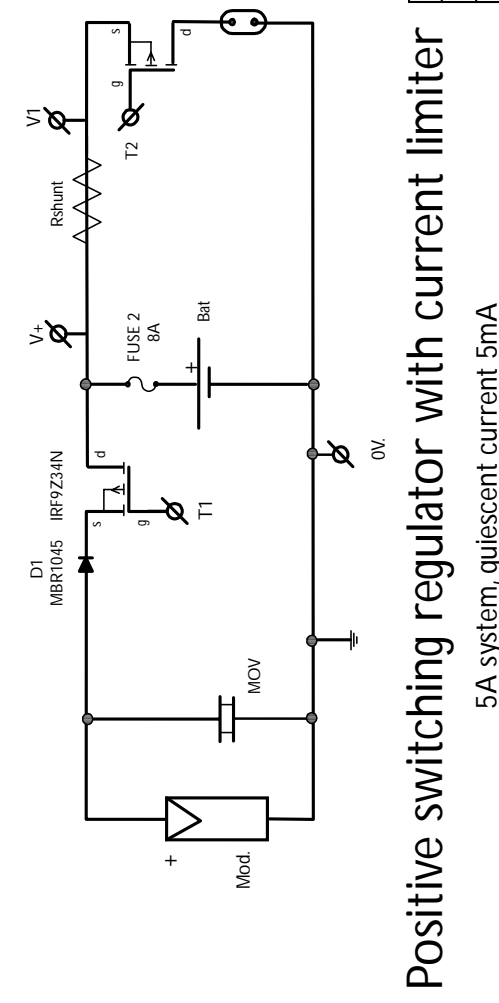
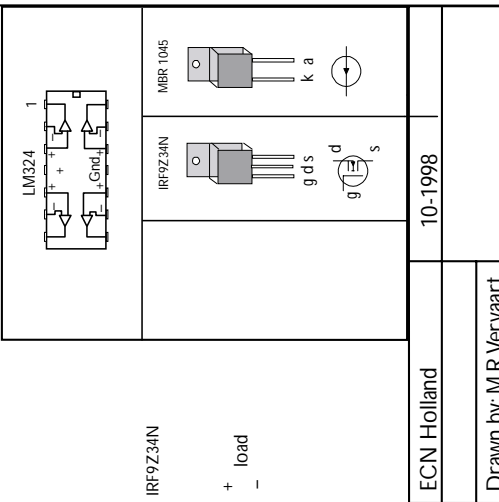
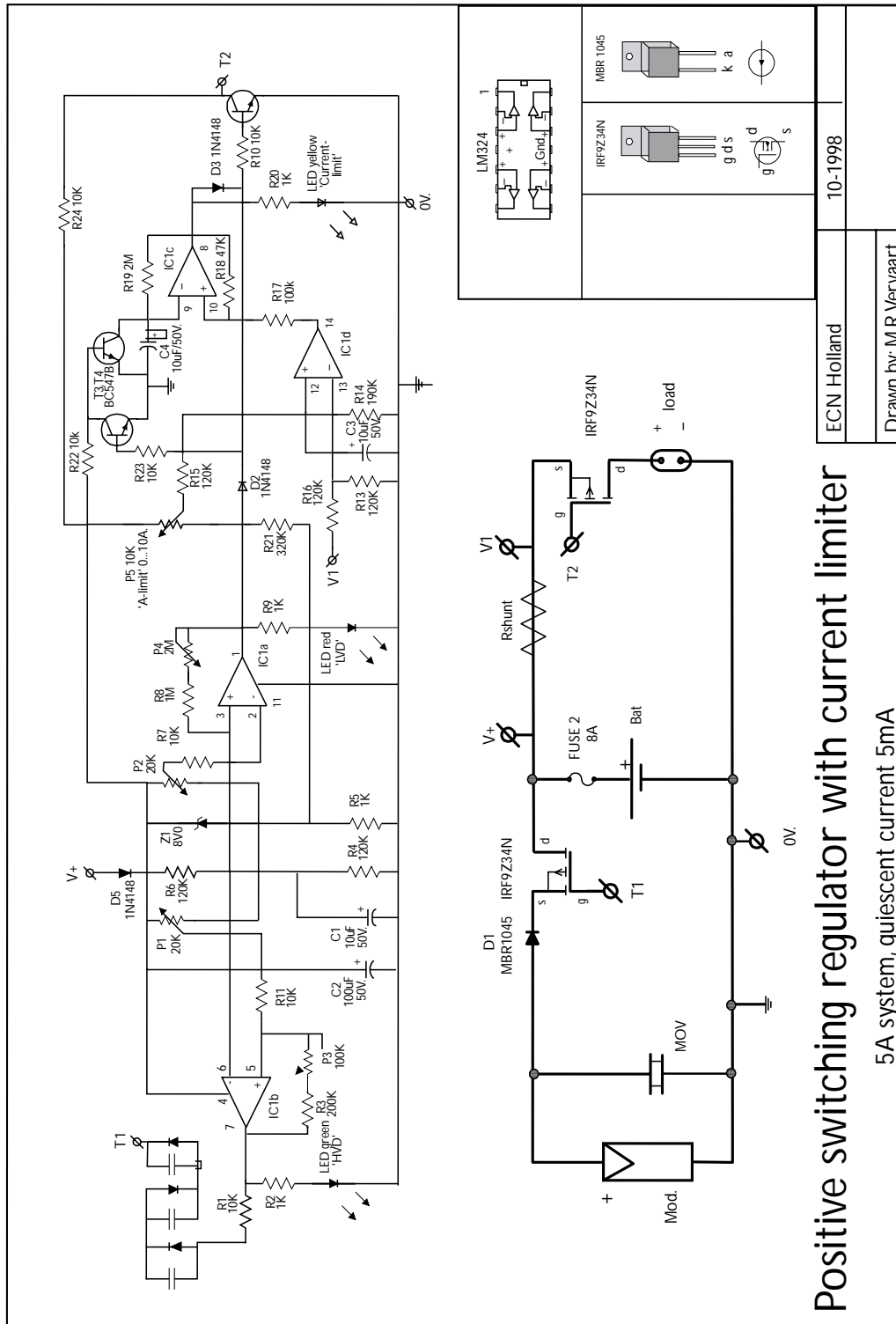

**Positive switching regulator with current limiter**

5A system, quiescent current 5mA

ECN Holland

10-1998

Drawn by: M.R. Vervaart

# Appendix 7

## 200VA HF Full-Bridge Inverter

The schematic in this appendix was originally intended to be printed on a much larger paper size. To view the detail more clearly, use the magnifying function in Acrobat Reader.

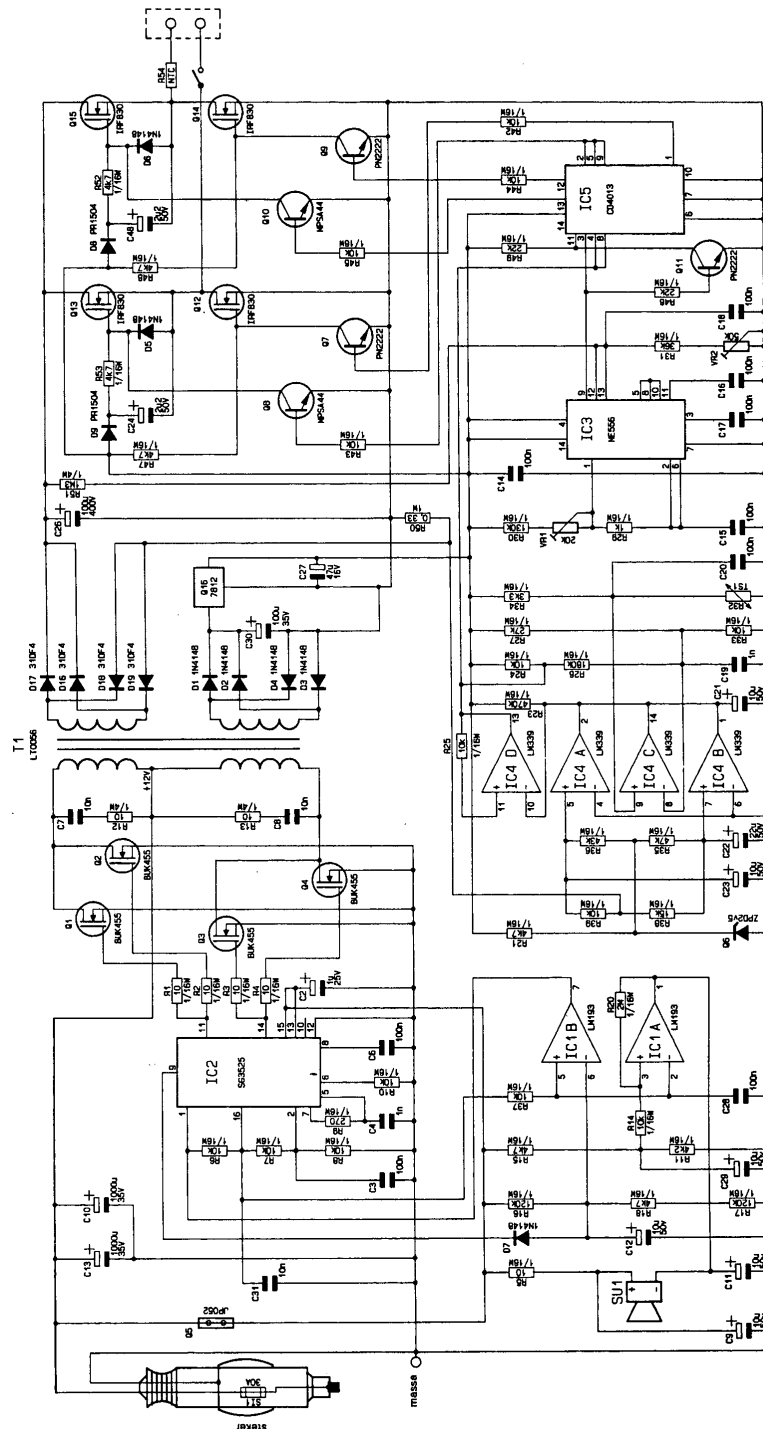

933506 - 11

# Appendix 8

## HF Full-Bridge Inverter Using Integrated Circuit HIP4082

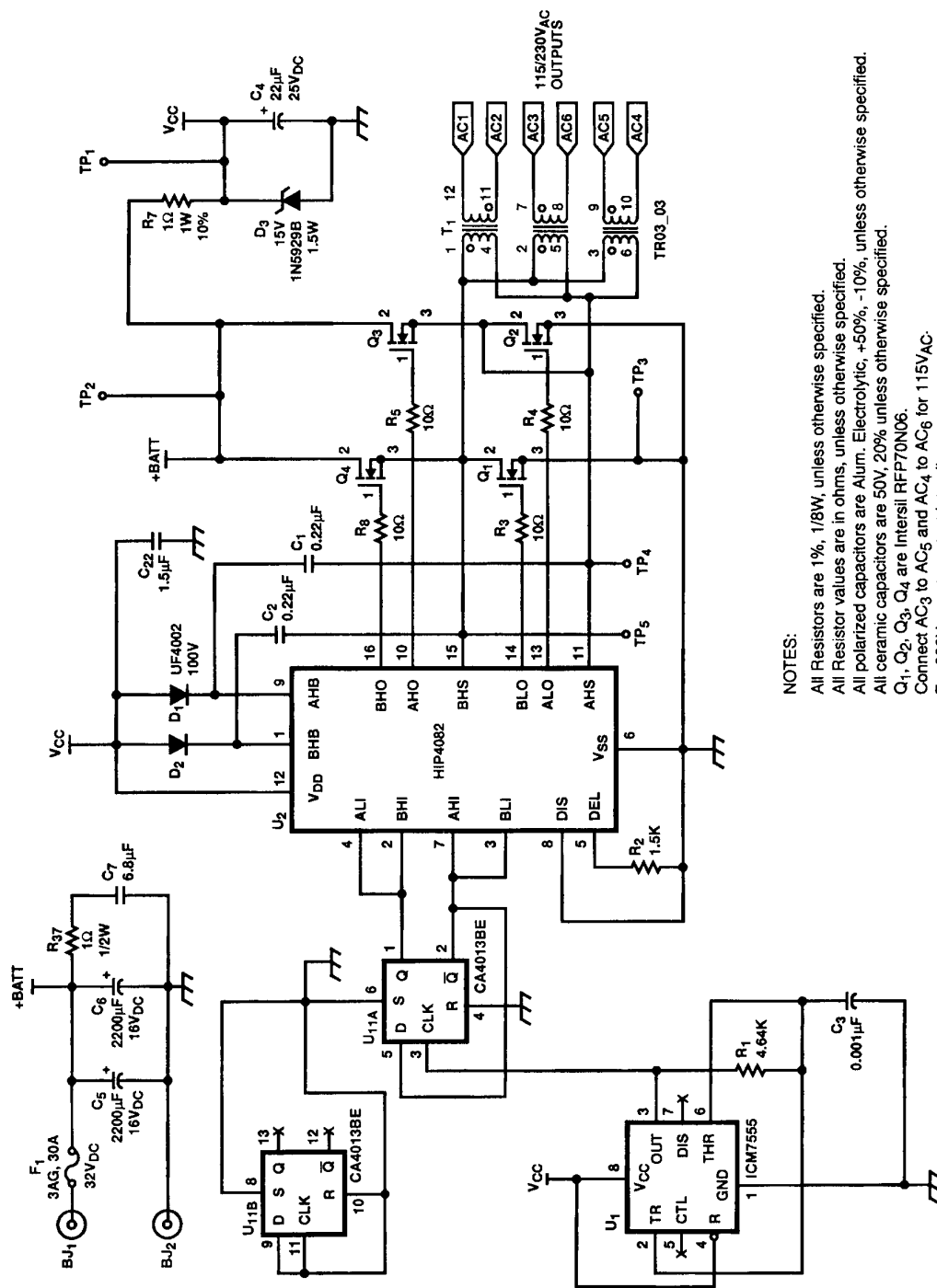

**NOTES:**  
 All Resistors are 1%, 1/8W, unless otherwise specified.  
 All Resistor values are in ohms, unless otherwise specified.  
 All polarized capacitors are Alum. Electrolytic, +50%, -10%, unless otherwise specified.  
 All ceramic capacitors are 50V, 20% unless otherwise specified.  
 Q1, Q2, Q3, Q4 are Intersil RFP70N06.  
 Connect AC3 to AC5 and AC4 to AC6 for 115VAC.  
 For 230VAC out, contact Intersil.

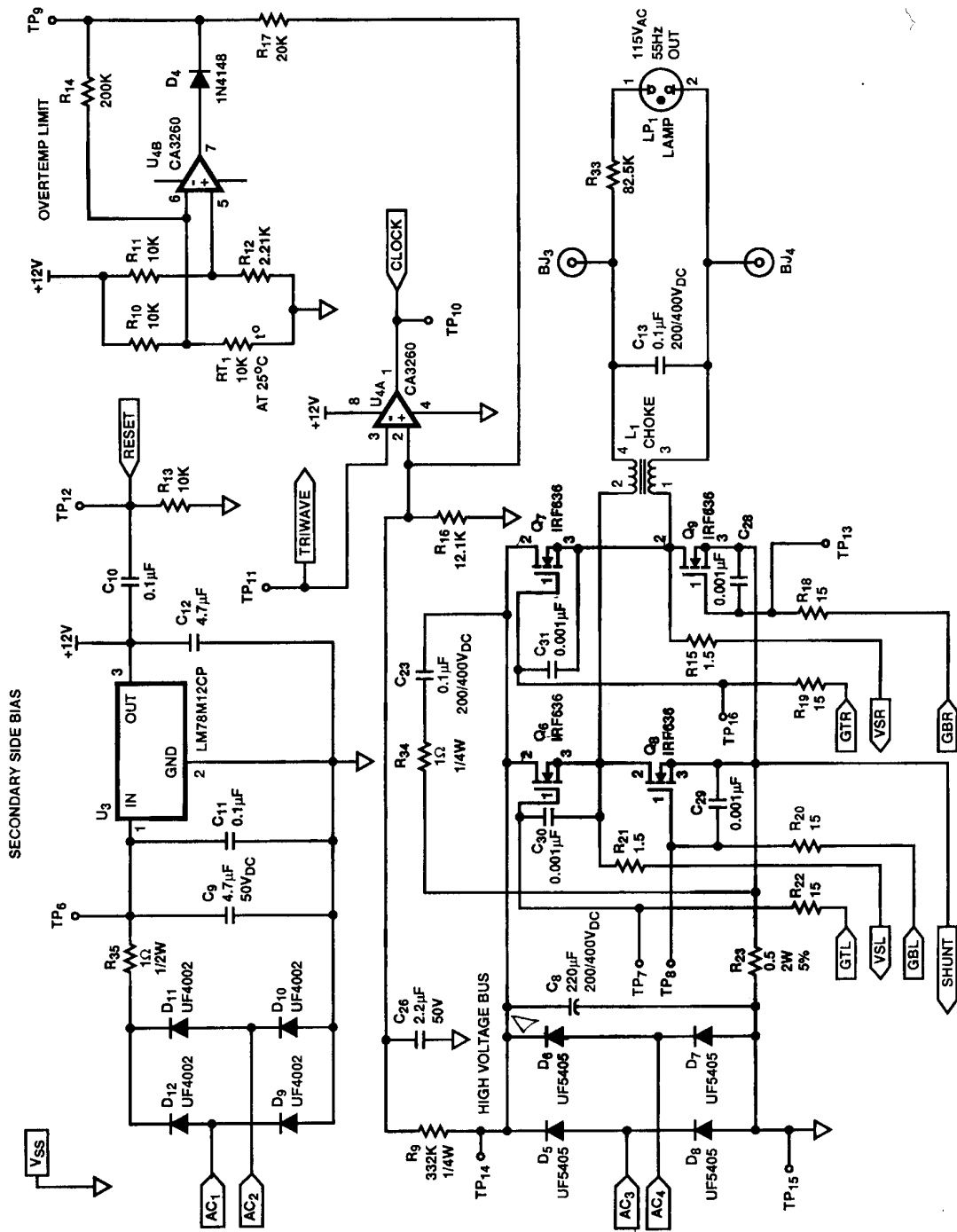

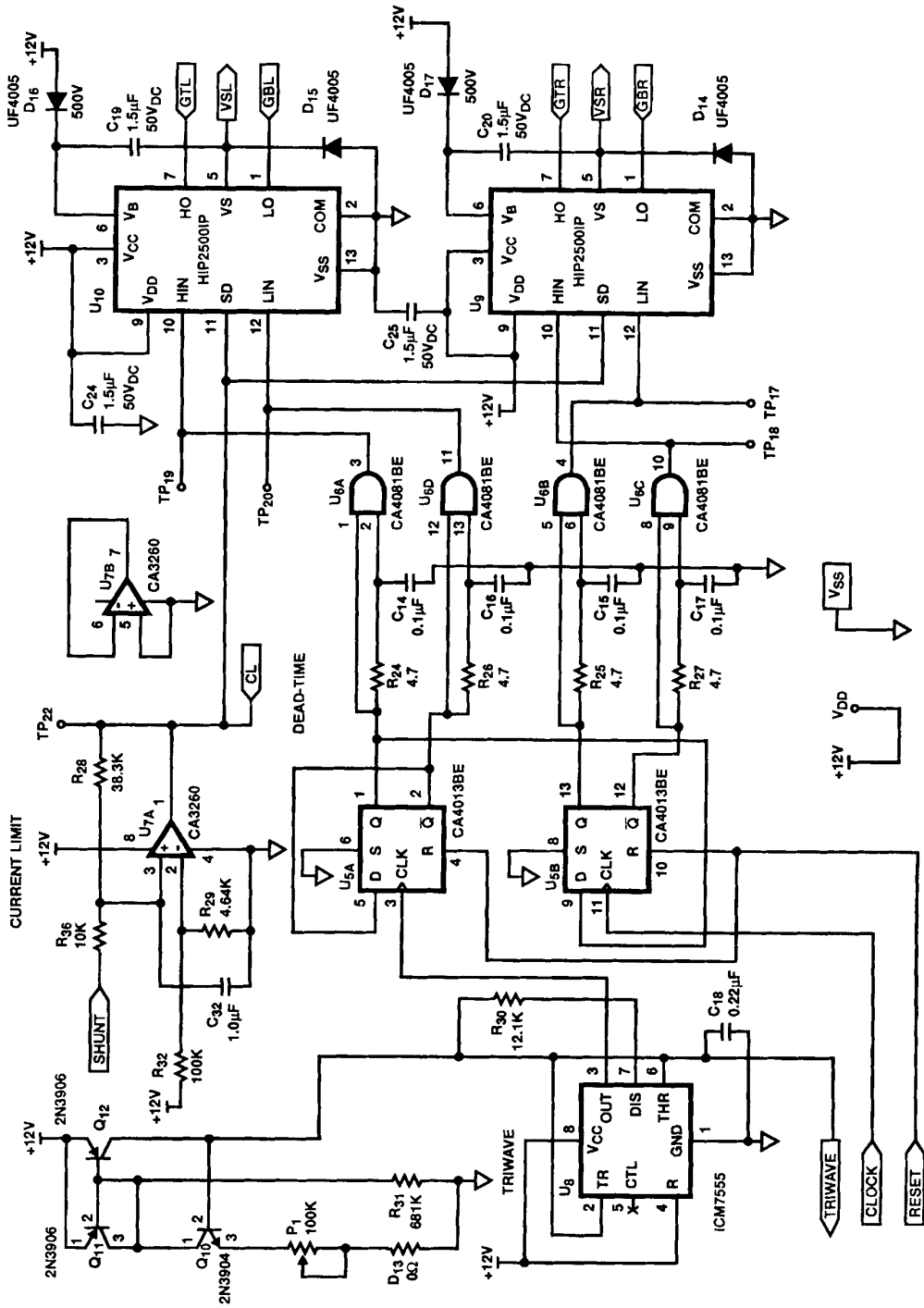

# Appendix 9

## Introduction to Light and Lighting

### Color and wavelength

Visible light is electromagnetic radiation in wavelengths for which the human eye is sensitive, that is, in the range of 400–800 nanometers (nm).<sup>❶</sup> Sensitivity is low for deep blue-colored short wavelengths. It peaks in the green at about 555 nm, and is low in the deep red at around 800 nm. An approximation of the sensitivity curve of the human eye is presented in figure A10.1. It shows the relative sensitivity as a function of wavelength. The maximum of 100 percent is reached at a wavelength of 555 nm.

Light output of a lamp: luminous flux[[H2]]

Since light is a form of energy, it is possible to express the light output of a lamp in units of power: watts. However, this would give very little information about the visual impression of the light. To quantify the amount of visible light, the spectral intensity of the light (see figure A2.5) is multiplied with the eye sensitivity curve (see figure A10.1) and added to obtain the luminous flux (Lu) in lumens (lm).

### Efficiency of lamp or luminaire: Luminous efficacy

The efficiency with which a lamp produces light in the visible spectrum is defined as the luminous flux per unit of power: lumens per watt.

### Luminous intensity

The amount of light emitted in a certain direction is the luminous intensity (Li). It is defined as the luminous flux per steradian, with the unit candela (cd). Since there are  $4\pi$  steradians in a sphere, the relation between the average luminous intensity  $Li_{av}$  and the luminous flux of light source is as follows:

$$Lu = 4 * \pi * Li_{av}$$

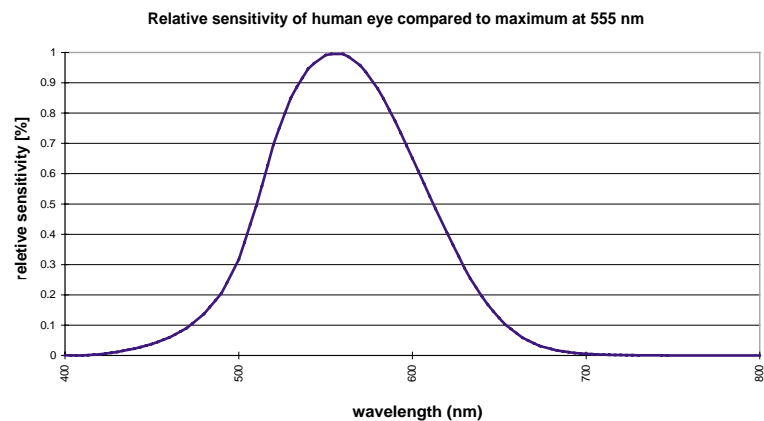

<sup>❶</sup> One nanometer is one-billionth ( $10^{-9}$ ) of a meter.

## Illuminance

A measure of how well a surface is lit is presented by the illuminance. It is defined as the luminous flux per unit of surface area. The unit is lux. 1 lux = 1 lumen per square meter. The illuminance  $E$  at a point with a distance  $d$  from the light source can be expressed as a function of the angle  $a$  between the beam of light and the surface:

$$E = (L_i/d^2) * \sin(a)$$

## Illuminous efficacy

Analogous to the luminous efficacy, the illuminous efficacy is a measure of the efficiency with which a light source illuminates a surface. It is presented in lux per watt.

## Correlated Color Temperature

The color appearances of the light source are expressed in the correlated color temperature (CCT). When the CCT is below 3,300 Kelvin, the light appears reddish. This is called warm white. With a CCT higher than 5,300 Kelvin, the light appears bluish. An intermediate appearance occurs with a CCT between 3,300 and 5,300 Kelvin.

## Color rendering

### Definition from *Rural Lighting: A Guide for Development Workers*.

The color of an object appears to differ when illuminated by different light sources. Color rendering is the degree to which the colors of surfaces illuminated by a given light source conform to those of the same surfaces under a reference. It is presented as a percentage. Good color rendering (80–90 percent) is achieved with incandescent lamps or fluorescent tubes with triphosphor coating. Moderate color rendering (60–80 percent) is achieved with standard fluorescent tubes.

# Appendix 10

## Equipment Needed for Practical Part of the Training Course

During the hands-on training, locally produced balance of system (BOS) components will be tested according to the local standards. After that, research will be done on how to improve the “weak spots” in the design. The manual provides various solutions for problems you might encounter in practice.

For the practical part, some basic equipment will be necessary to do proper measurements and to modify the electronics thereafter. In the ideal case, the work can be done in an electronic research and development laboratory. Depending on the number of participants, you can form multiple groups. In this way, you can run several tests simultaneously and use the time more efficiently. The critical factor is the limited amount of hardware available.

The basic materials needed are charge regulators, fluorescent lamps inverters (FLIs), and DC-AC converters. Following are the recommendations:

### Charge regulators

- At least two samples of one type of a locally manufactured charge regulator.
- Two digital multimeters.
- Power-supply 0–30 V, 0–10 A (depending on the maximum current rating of the charge regulator).
- Trimmable load 0–10 A (depending on the maximum current rating of the charge regulator).

In the case of a pulse-width modulation (PWM) charge regulator, an oscilloscope is recommended.

### Fluorescent lamps inverters (FLIs)

- At least two samples of one type of a locally manufactured FLI.
- One or two digital multimeters.
- Digital oscilloscope with computer connection or floppy drive (to measure electrical efficiency and to handle pictures in the final report of the course).
- A personal computer with Excel and Word.

### DC-AC converters

- Power-supply 0–20V, 0–20A (depending on the max. power rating of the DC/AC-inverter)
- For the rest the above listed materials will be used for these measurements

### General

- The locally applied standards for these three BOS components, when available.
- Two soldering irons and soldering material.
- Some stock of standard electronic components (resistors, capacitors, transistors, some power MOSFETs p- or n-type, and material for making transformers for FLIs).

These basic materials can be shared by the different groups. For example, two or three multimeters and an oscilloscope can be used by all groups.

# Appendix 11

## Training Program Evaluation

### Mitigating Global Climate Change through the Development of a Quality Process Infrastructure for Renewable Energy (Quap-PV)

Please complete the questionnaire, and hand in before leaving.

Optional: If you do not want to give your name, you do not need to. The main priority is to get your feedback.

**Name:** \_\_\_\_\_

**Organization:** \_\_\_\_\_

**Phone:** \_\_\_\_\_

**Fax:** \_\_\_\_\_

### Design and Modification of BOS Components

#### *Contents*

	Good		Average		Bad
Contents of the course	<input type="radio"/>	<input type="radio"/>	<input type="radio"/>	<input type="radio"/>	<input type="radio"/>
Usefulness of the course	<input type="radio"/>	<input type="radio"/>	<input type="radio"/>	<input type="radio"/>	<input type="radio"/>

#### *Training material*

	Good		Average		Bad
Quality of the training manual	<input type="radio"/>	<input type="radio"/>	<input type="radio"/>	<input type="radio"/>	<input type="radio"/>
Quality of the overhead sheets	<input type="radio"/>	<input type="radio"/>	<input type="radio"/>	<input type="radio"/>	<input type="radio"/>
Usefulness of the training manual	<input type="radio"/>	<input type="radio"/>	<input type="radio"/>	<input type="radio"/>	<input type="radio"/>
Completeness of the training manual	<input type="radio"/>	<input type="radio"/>	<input type="radio"/>	<input type="radio"/>	<input type="radio"/>

Which topics in the manual could be left out? \_\_\_\_\_

Which topics were missing in the manual? \_\_\_\_\_

Which topics in the manual could be briefer? \_\_\_\_\_

Which topic in the manual could be expanded? \_\_\_\_\_

*Exercises (hands-on training)*

Did you participate in the hands-on training?                      Yes                       No

**If yes, did it give a good insight into how to design and modify BOS electronics?**    Yes     No

**If no, what can be added to the hands-on training?** \_\_\_\_\_

\_\_\_\_\_

If you participated in the hands-on training, how good was it?

Good		Average		Bad
<input type="radio"/>	<input type="radio"/>	<input type="radio"/>	<input type="radio"/>	<input type="radio"/>

*Presentation of the Lectures*

	Good		Average		Bad
How well did the instructor present the material?	<input type="radio"/>	<input type="radio"/>	<input type="radio"/>	<input type="radio"/>	<input type="radio"/>

How well did the instructor respond to questions?	<input type="radio"/>	<input type="radio"/>	<input type="radio"/>	<input type="radio"/>	<input type="radio"/>
---	-----------------------	-----------------------	-----------------------	-----------------------	-----------------------

How well did the instructor involve the participants?	<input type="radio"/>	<input type="radio"/>	<input type="radio"/>	<input type="radio"/>	<input type="radio"/>
---	-----------------------	-----------------------	-----------------------	-----------------------	-----------------------



# Appendix 12

## Sample Checklist

Test Report for Low Voltage DC Lights for Solar Home Systems	
Project No.:	Manufacturer: Name of unit: Type of Unit: Type Number : Serial number:
Client:	
Tested by: M van Leeuwen	
Test Batch Number: Date: Sheet of	

Description of test			Okay/Fail/ Value	Comments
<b>1.General Inspection</b>				
(C-G 8)	Visual Inspection			
(-G 9.1)	Funtional Test	DC range 10 Vdc -16Vdc or Manufacturers Spec.		
2.4	Visual Inspection	Terminals, Safety Earth		
2.5	Visual Inspection	Creepage		
2.9	Visual Inspection	Accidental Contact to live parts		
<b>2.Safety</b>				
2.1(-G 9.)	Insulation resistance	48hr @ 91%-95% RH, 20-30 Celsius	> 2 M Ohm	
2.2	Dielectric Strenght	50 Hz @ 500Vac	No Flashover	
2.3	Pulse Voltage	16Vdc + 3 x 16Vpeak,10ms		
2.7	Fault condition test			
<b>Abnormal Conditions</b>				
2.8.1	Lamp removal	1 Hour @ 16Vdc		
2.8.2	Lamp Failure	Filament resistor for 1 hr	( IEC 0081)	
2.8.3	Reverse Polarity	Blocking Diode		
<b>3.Performance Tests</b>				
3.1	Cold Start	12Vdc +/- 10% @ 10 up to 35 degrees Celsius		
	Operation	12Vdc +/- 10% @ 10 up to 50 degrees Celsius		
3.2	Open circuit lamp Voltage	@ 16Vdc	Vpk	
3.3	Lamp Current	@ 12Vdc	mA	
3.4	Inom.	@ 12Vdc	mA	
3.5	Max. Curent Electrode Supply.	@ 12Vdc	mA	
3.6	Lamp waveform @ I nom	@ 12Vdc		
3.7	see functional test			
		<b>Vdc input</b>	<b>A</b>	<b>Watt</b>
	Input power P @ 10Vdc	10		
3.8	Input power P @ 16Vdc	16		
3.9	Luminous Efficacy @ 2000 hr burning period			
<b>4.Endurance Test</b>				
4.1	100 hr. burn-in Luminous Flux			
4.2	10,000 Switching Test	60 sec On,120 sec. Off		
5.EMC	See Separate test report			

Comments

Test Report for Low Voltage DC PV Charger Controllers for Solar Home Systems	
Project No.:	Manufacturer: Name of unit: Type of Unit: Type Number : Serial number: Number of samples:
Client:	
Tested by:	Test Batch Number: Date: Sheet

**Documentation**

4.1.1, 4.1.2, 4.1.3

- \* Installation, Operating and trouble shooting instructions
- \* Warranty
- \* Conditions of surroundings
- \* Physical properties of the charge regulator
- \* Electrical properties of the charge regulator

Yes	No
<input type="checkbox"/>	<input type="checkbox"/>
<input type="checkbox"/>	<input type="checkbox"/>
<input type="checkbox"/>	<input type="checkbox"/>
<input type="checkbox"/>	<input type="checkbox"/>
<input type="checkbox"/>	<input type="checkbox"/>

Comments

**6. Marking**

- \* Maximum Module & Load Current
- \* Nominal voltage
- \* Polarity display
- \* Labeling displays
- \* Fuse values

<input type="checkbox"/>	<input type="checkbox"/>
<input type="checkbox"/>	<input type="checkbox"/>
<input type="checkbox"/>	<input type="checkbox"/>
<input type="checkbox"/>	<input type="checkbox"/>
<input type="checkbox"/>	<input type="checkbox"/>

**8. Electrical Parameters**

8.1 Nominal Voltage

12V.	24V.
<input type="checkbox"/>	<input type="checkbox"/>

8.2

Working principle Voltage control  
SOC algorithm

Switching polarity

(PWM, Shunt or series)

<input type="checkbox"/>
<input type="checkbox"/>
<input type="checkbox"/>
<input type="checkbox"/>

+                      -

<input type="checkbox"/>	<input type="checkbox"/>
--------------------------	--------------------------

8.3 Switching thresholds

I<sub>mod</sub>=25%  
I<sub>load</sub>=25%

Genelec  
HVD 2.30 V/cell  
HVR 2.25 V/cell  
LVD 1.90 V/cell  
LVR 2.10 V/cell

Y	N
<input type="checkbox"/>	<input type="checkbox"/>
<input type="checkbox"/>	<input type="checkbox"/>
<input type="checkbox"/>	<input type="checkbox"/>
<input type="checkbox"/>	<input type="checkbox"/>

8.5 Status Indicator Display

<input type="checkbox"/>
--------------------------

**Visual Inspection**

9.

- Damage to the case, on terminals or displays
- Quality of case
- Quality of Electronic system
- Quality of wiring

O.K.	Comments
<input type="checkbox"/>	<input type="checkbox"/>
<input type="checkbox"/>	<input type="checkbox"/>
<input type="checkbox"/>	<input type="checkbox"/>
<input type="checkbox"/>	<input type="checkbox"/>

**10.1 Function test**

**End of charge voltages**

HVD  
HVR

I <sub>load</sub> :	I <sub>mod</sub> 6A		
	0A	3A	4,0 A
LVD	<input type="checkbox"/>	<input type="checkbox"/>	<input type="checkbox"/>
LVR	<input type="checkbox"/>	<input type="checkbox"/>	<input type="checkbox"/>

<input type="checkbox"/>	V
<input type="checkbox"/>	V

Gassing voltage (NP = Not present)

<input type="checkbox"/>	np
--------------------------	----

**Performance test**

Quiescent current  
Voltage drop Module-Battery I<sub>mod</sub> 6A  
Voltage drop Battery-Load I<sub>load</sub> 4.08 A

V at:

<input type="checkbox"/>	mA.
<input type="checkbox"/>	V.
<input type="checkbox"/>	V.

Voltage drop compensation  
If yes, dV Battery terminal / Threshold controller < 100mV

Y	N
<input type="checkbox"/>	<input type="checkbox"/>
<input type="checkbox"/>	<input type="checkbox"/>

# Abbreviations and Special Terms

<b>AC</b>	Alternating current—flow alternates current in cycles called Hertz (Hz).
<b>ADC</b>	Analog digital conversion
<b>Ballast</b>	High-frequency inverter, used for driving a fluorescent lamp.
<b>B-H</b>	Created flux density (B) versus field intensity (H)
<b>BJT</b>	Bipolar junction transistor
<b>BOS</b>	Balance of system
<b>CFL</b>	Compact fluorescent lamp
<b>CMOS</b>	Complementary metal-oxide semiconductor
<b>DC</b>	Direct current—current flows in only one direction
<b>D.C.</b>	Duty cycle
<b>EEPROM</b>	Electric erasable programmable read only memory
<b>elco</b>	Electrolytic capacitor
<b>ECN</b>	Netherlands Energy Research Foundation (Energieonderzoek Centrum Nederland)
<b>EMC</b>	Electromagnetic
<b>EMF</b>	Electromagnetic force
<b>EMI</b>	Electromagnetic inductance
<b>ESR</b>	Electrostatic resistance
<b>FET</b>	Field-effect transistor
<b>FL</b>	Fluorescent lamp
<b>FLI</b>	Fluorescent lamp inverter
<b>GTO</b>	Gate transmission opener
<b>HVD</b>	High-voltage disconnect—the instant in time when the module is disconnected from the system in order to stop battery charging
<b>HVR</b>	High-voltage reconnect—the instant in time when the module is reconnected to the system
<b>IC</b>	Integrated circuit
<b>IEA PVPS</b>	International Energy Agency—Photo Voltaic Power Systems
<b>IEC</b>	International Electrotechnical Commission
<b>IGBT</b>	Insulated gate bipolar transistor
<b>LC</b>	Circuit with an inductance (L) and capacitor (C)
<b>L-C filter</b>	Filter, based on an inductor and a capacitor
<b>LED</b>	Light-emitting diode
<b>LRC</b>	Circuit with a resistor, inductor, and capacity
<b>LVD</b>	Low-voltage disconnect—the instant in time when the load is disconnected from the system because of a low battery
<b>LVR</b>	Low-voltage reconnect—the instant in time when the load is reconnected to the system and energy use is enabled
<b>MOSFET</b>	Metal-oxide semiconductor field-effect transistor
<b>MOV</b>	Metal-oxide varistor
<b>NOCT</b>	Nominal operating cell temperature
<b>opamp</b>	Operational amplifier
<b>PCB</b>	Printed circuit board
<b>PV</b>	Photovoltaic
<b>PW</b>	Pulse width

<b>PWM</b>	Pulse-width modulation
<b>QNOT</b>	The inverted output of a flip-flop
<b>RC</b>	Circuit with resistance and capacity
<b>RMS</b>	Root mean square
<b>SHS</b>	Solar home system
<b>SLI</b>	Starting, lighting, ignition (battery)
<b>SOC</b>	State of charge (of the battery)
<b>STC</b>	Standard test conditions
<b>TVS</b>	Transient voltage suppressor
<b>VCO</b>	Voltage control oscillator
<b>VHF</b>	Very high frequency
<b>VR</b>	Valve regulated (batteries)
<b>VSI</b>	Voltage-source inverter

**Crest factor** = (Peak voltage) / (RMS voltage)

**Duty cycle** = (on-time/off-time) x 100%

**Electrical efficiency** = (Output power) / (input power) x 100%

## Units of Measure

**Ampere (A)** The standard unit for measuring the strength of an electric current.

**Ampere-hour** The standard unit for measuring the quantity of electricity, equal to the flow of a current of one ampere for one hour.

**Amplitude** The extreme range of a fluctuating quantity, as an alternating current, generally measured from the average or the mean to the extreme.

**Celsius (°C)** A scale on which 0° is the freezing point and 100° is the boiling point of water.

**Coulomb (C)** Charge transported through a conductor by a current of one ampere flowing for one second.

**Hertz (Hz)** The international unit of frequency, equal to one cycle per second.

**Joule** The amount of work done by one newton acting through a distance of one meter.

**Kilohertz (kHz)** 1,000 hertz.

**Lumen (lm)** A unit of measure for the flow of light, equal to the amount of flow through a unit solid angle from a uniform point source of one candela.

**Lux (lx)** A unit of measure equal to one lumen per square meter or to the illumination of a surface uniformly one meter distant from a point source of one candela.

**Newton (N)** Force that imparts to a mass of one kilogram an acceleration of one meter per second per second.

**Ohm ( )** Electrical resistance, measured in volts per ampere.

**Volt (V)** The unit of electromotive force between two points in an electric field that requires one joule of work to move a positive charge one coulomb from the point of lower potential to the point of higher potential.

**Voltage** Electromotive force expressed in volts.

**Watt (W)** The unit of electrical power equal to one joule per second or to the power developed in a circuit by a current of one ampere flowing through a potential difference of one volt.

**Watt-peak (Wp)** At a solar radiation of 1,000 W/m<sup>2</sup>, at 25°C and with an air mass of 1.5, 1 watt-peak delivers 1 W energy.

**Watt-hour (Wh)** A unit of electrical energy or work equal to 1 watt acting for 1 hour, or 3,600 joules.

# References

- Andersson, Bo, Catella Generics, and Staffan Ulvonas. *Battery Guide for Small Stand Alone Photovoltaic Systems*. IEA PVPS Task III.
- Cabraal, Anil, Mac Cosgrove-Davies, and Loretta Schaeffer. 1996. *Best Practices for Photovoltaic Household Electrification Programs; Lessons from Experiences in Selected Countries*. Technical Paper No. 324. Washington, D.C.: World Bank.
- ECN. "Rural Lighting Services: A Comparison of Lamps for Domestic Lighting in Developing Countries." Petten, Netherlands: ECN.
- ELV GmbH. 1993. *200Watt PowerInverter*. Holland: Elektuur uitgeverij.
- Gerken, K., and D. Welsch. February 1997. *A Pulse-Width Modulated High Reliability Charge Controller for Small Photovoltaic Systems*. Report SAND97-0329. Albuquerque, New Mexico: Sandia National Laboratories.
- Intersil. 1996. *A DC-AC Isolated Battery Inverter Using HIP4082*. Palm Bay, Florida, U.S.A.: Application note at <http://www.intersil.com>.
- Khan, Hasna J., Rezwana Khan, and Salma Khatun. 1998. *Optimal Design of DC Luminaires for Solar PV Applications*. Final draft. Prepared for the World Bank.
- Louineau, Jean-Paul, Mobido Dicko, Peter Fraenkel, Roy Barlow, and Varis Bokalders. 1994. *Rural Lighting: A Guide for Development Workers*. Stockholm: IT Publications in association with the Stockholm Environment Institute.
- Mohan, Ned, Tore M. Undeland, and William P. Robbins. 1995. *Power Electronics: Converters, Applications and Design*. New York: John Wiley and Sons.
- Nieuwenhout, F. D. J., P. J. N. M. van de Rijt, and E.J. Wiggelinkhuizen. 1998. *Rural Lighting Services: A Comparison of Lamps for Domestic Lighting in Developing Countries*. Petten, the Netherlands: Netherlands Energy Research Foundation (ECN).
- OTTI Technologie-Kolleg. May 1999. *Erstes Fachforum Wiederaufladbare Batteriesysteme*. Regensburg, Germany: OTTI.
- Petrus, Tri Bakti. 1997. *Perancangan DC Ballast Inverter*. Jakarta, Indonesia: PT Len.
- Séguier, Guy, and Francis Labrique. 1993. *Power Electronic Converters: DC-AC Conversion*. Berlin and Heidelberg: Springer Verlag.

